



JA28

JET AIR OVEN (JA28)

The JA Series from DOYON is known worldwide for its unique and patented JET AIR SYSTEM (the air moves in one direction for 2.5 minutes, stops for 25 seconds then moves the other way for 2.5 minutes) resulting in a gentle velocity air flow for exceptional baking results. This system will help you bake faster and more evenly without having to turn your pans at half of the baking time. (Ex: Competitors units will bake only one side or unevenly : muffins blow over, bakes only the outside, etc). Our competitors ovens allow the air to move in one direction only. DOYON ovens will bake better and your employees will continue preparations without worrying about turning pans.

DOYON's outstanding uniform steam injection system includes an electronic timer which will give you a precise mist everytime for a better quality product (crusty breads, bagels, french baguettes, etc.). This superior steam system will allow inexperienced employees to produce quality products with a minimum of training.

VERSATILITY:

Bread, rolls, buns, crusty breads, pastries, muffins, cookies, cakes, pies, bagels, croissants, sours and ryes, pizzas, hamburgers, bacon, game hens, chicken, turkey, multimeal prep, bulk vegetables/casseroles, slow cook/retherm.

JA28

“Simply the **best**
bakery oven on
today's **market !**”

Jet Air Oven 28 pans baking capacity

OVEN FEATURING

- Four separate ovens with separate controls
- Exclusive patented reversing fan system
- Outstanding steam injection system including an electronic timer
- Compact space saving unit
- High production oven (28 pans)
- Full view heat reflective thermos glass doors
- Brightly lit
- Digital reminder timer
- Fully insulated, completely sealed
- Digital temperature controllers and timers
- Temperature up to a maximum of 500° F (260°C)
- Energy efficient electric or gas heating (baking temperature reached in 15 minutes)
- Magnetic latches
- Door switch cut-off for fan blower
- Locking casters
- Stainless steel inside and outside
- 3/4 HP motor
- NSF & ETL listed
- One year parts and labor limited warranty

OPTIONAL

- Programmable controls (adds 4" to oven width)
- Water softener system
- Auto steam
- Delay switch (electric model only)
- Gas quick disconnect kit (4' flexible hose, ball valve and securing device)

*All Jet Air ovens can
be used to cook meat*

OVERALL DIMENSIONS

72 1/4" W X 49 1/4" D X 72 3/4" H (electric model)
 (1835 mm X 1250 mm X 1850 mm)
 72 1/4" W X 53 1/2" D X 72 3/4" H (gas model)
 (1835 mm X 1360 mm X 1850 mm)

OVEN INTERIOR DIMENSIONS

25 1/2" W X 30 1/2" D X 28" H (electric model)
 (648 mm X 775 mm X 711 mm)
 25 1/2" W X 29 1/2" D X 28" H (gas model)
 (648 mm X 749 mm X 711 mm)

Shelf spacing 3 1/4" (83 mm)

GAS SYSTEM (JA28G - Propane or natural)
BTU total: 260 000 (65 000 per oven)
 120/240V - 1 PH - 18 A - 4 kW - 3 wires - 60 Hz
 120/208V - 3 PH - 12 A - 4 kW - 4 wires - 60 Hz

Gas Inlet : 3/4" NPT

Recommended gas pressure:

Propane gas : 11" W.C.
 Natural gas : 7" W.C.

ELECTRICAL SYSTEM (JA28)

3 phases:
 120/208V - 119A - 43 kW - 4 wires - 60 Hz
 120/240V - 105A - 43 kW - 4 wires - 60 Hz
 220/380V - 61A - 37 kW - 4 wires - 50 Hz

Other voltages available

Water Inlet : 1/4" NPT

OVEN CAPACITY

TOTAL
 Standard sheet pans 18" X 26" (46 cm X 66 cm): 28 pans
 Four-strapped bread pans: 112 loaves
 9" (23 cm) pies: 196 pies

FINISH

Stainless steel

SHIPPING INFORMATION

1975 lb (897 kg) approximately (JA28)
 2335 lb (1060 kg) approximately (JA28G)

Electrical service connection and water inlet are located at the back of the unit.

Specifications and design subject to change without notice.

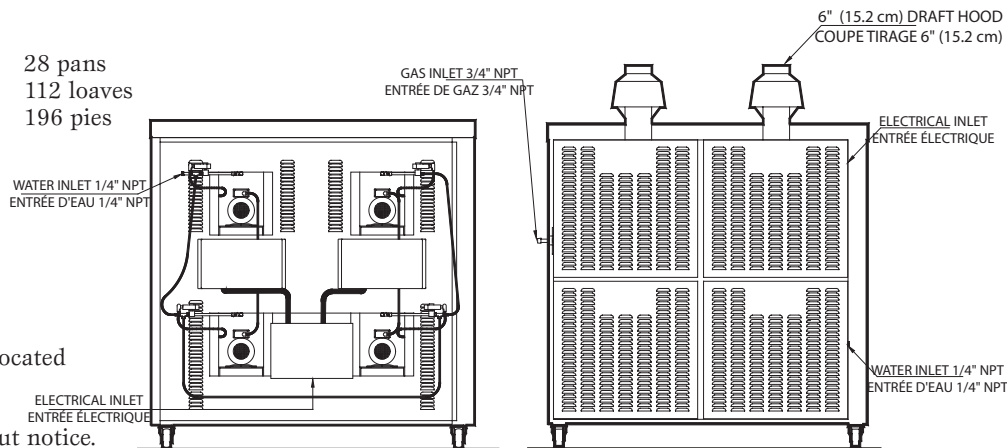
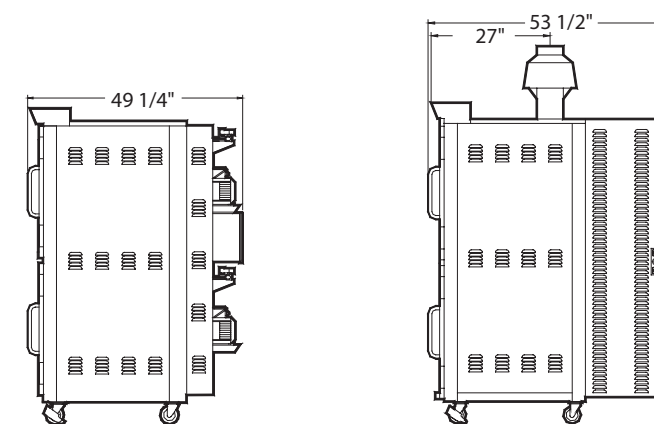
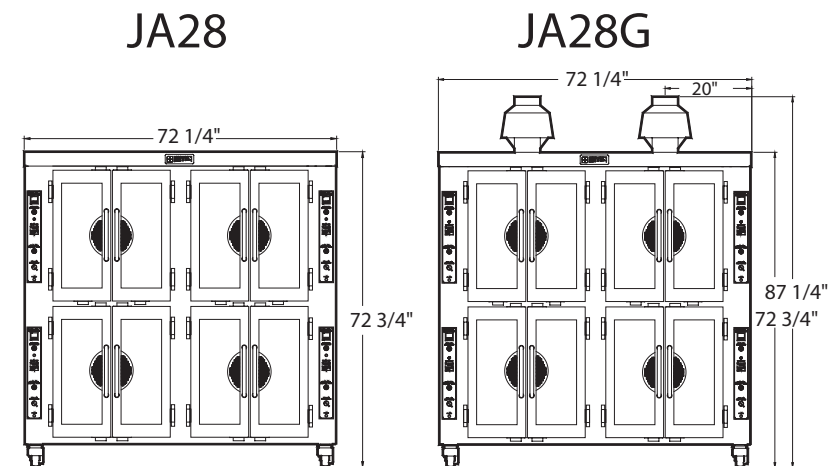

Your local distributor:

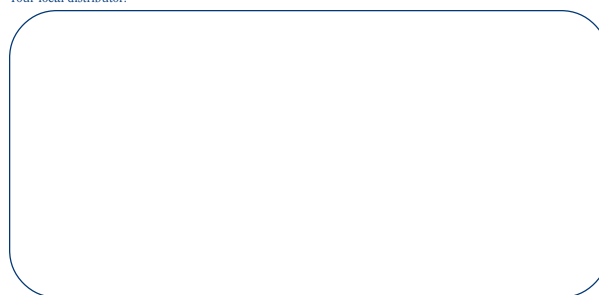

1255, rue Principale
 Linière, Beauce, Québec, Canada G0M 1J0

Telephone.: 418-685-3431
 Canada: 1-800-463-1636
 E-mail : doyon@doyon.qc.ca

Fax: 418-685-3948
 U.S.: 1-800-463-4273
 Internet : http://www.doyon.qc.ca

Printed in Canada Rev: 052006b