



FC18



FC18D



FC18-3



FC18-2

### FC18 Series conveyor ovens

Doyon fast conveyor ovens are your best buy to increase production in less space, bake 30% to 50% faster than traditional ovens, improve product consistency, reduce labor costs and minimize energy costs by 35% to 65%. Predetermine belt speed (cooking time) and temperature, place the food on the moving conveyor belt and remove for perfect results everytime. With a 19 1/2" X 3 3/4" (495 mm X 95 mm) opening and an increased production per square foot, Doyon conveyor ovens are not only the strongest of the industry, they are the most attractively priced of their category.

## FC18

"Superior **quality** product  
at an **affordable** price!"

### Conveyor ovens FEATURING

- Compact and stackable (up to 3 high).
- Jets of high velocity hot air delivered to food.
- Faster consistent cooking than traditional, infrared and convection ovens.
- Guaranteed even baking.
- First in, first out.
- Allow inexperienced employees to produce quality products with a minimum of training.
- Bake pizzas in 5 to 6 minutes.
- Save on labor costs.
- Save on energy bills.
- 18" (457 mm) wide stainless steel belt with a 19 1/2" (495 mm) opening.
- Adjustable speed and temperature.
- Better moisture retention.
- Low maintenance and easy cleaning.
- Shipped fully assembled.
- Stand included.
- Temperature up to 600°F (300°C).
- Exhaust hood required above the unit(gas models).
- Available in gas or electric.
- ETL and ETL sanitation listed.
- One year parts and labor limited warranty.

### OPTIONAL

- Front access glass door with a 18 1/4" X 5 3/8" (464 mm X 137 mm) opening (FC18D).
- Lock for control panel (FC18L).

**DIMENSIONS with stand (gas and electric models)**

<b>FC18</b>	58"W	X 42 3/4"D	X 48 1/2"H
	(1475 mm)	X (1085 mm)	X (1230 mm)
<b>FC18-2</b>	58"W	X 42 3/4"D	X 60 3/4"H
	(1475 mm)	X (1085 mm)	X (1545 mm)
<b>FC18-3</b>	58"W	X 42 3/4"D	X 66 1/4"H
	(1475 mm)	X (1085 mm)	X (1685 mm)

**BAKING CHAMBER DIMENSIONS**

28 1/2"W	X 19 1/2"D	X 3 3/4"H
(724 mm)	X (495 mm)	X (95 mm)

**GAS SYSTEM (FC18G - Natural or propane)**

52 000 BTU per unit  
 120V - 1 PH - 8 A - 1 kW - 2 wires - 60 Hz NEMA 5-15P  
 220V - 1 PH - 5 A - 1 kW - 2 wires - 50 Hz

**EXHAUST HOOD REQUIRED ABOVE UNIT**

Gas inlet : 1/2" NPT

**Recommended gas pressure:**

Propane gas : 11" W.C.  
 Natural gas : 7" W.C.

**ELECTRICAL SYSTEM (per unit)**

FC18 :  
 120/208V - 1 PH - 59 A - 12 kW - 3 wires - 60 Hz  
 120/240V - 1 PH - 52 A - 12 kW - 3 wires - 60 Hz  
 120/208V - 3 PH - 39 A - 12 kW - 4 wires - 60 Hz  
 220V - 1 PH - 61 A - 13 kW - 2 wires - 50 Hz  
 220/380V - 3 PH - 24 A - 13 kW - 4 wires - 50 Hz

**PRODUCTION PER HOUR PER UNIT (500°F/260°C - 5 min)**

19 - 18" Pizzas  
 70 - 9" Pizzas  
 150 - 6" Pizzas

**SHIPPING WEIGHT**

700 lbs per unit (318 kg) approximately (electric unit)  
 800 lbs per unit (363 kg) approximately (gas unit)

Specifications and design subject to change without notice.

**FC18**

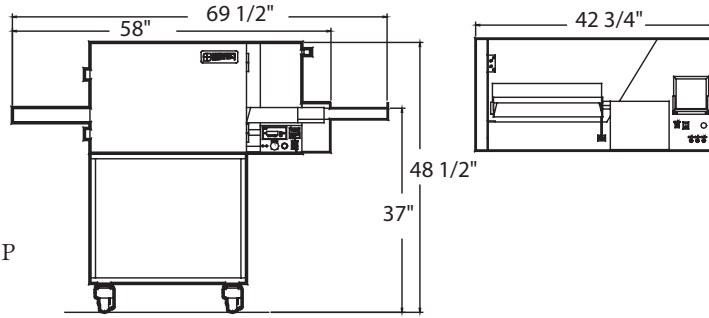

**TOP VIEW  
 VUE DU DESSUS**

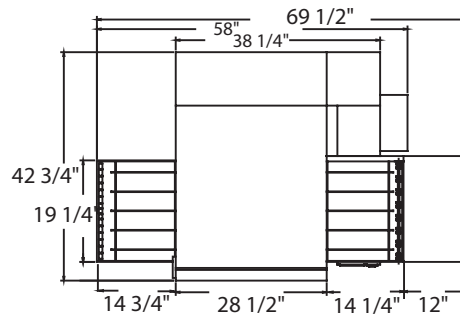

**FC18 - 2**

**FC18 - 3**

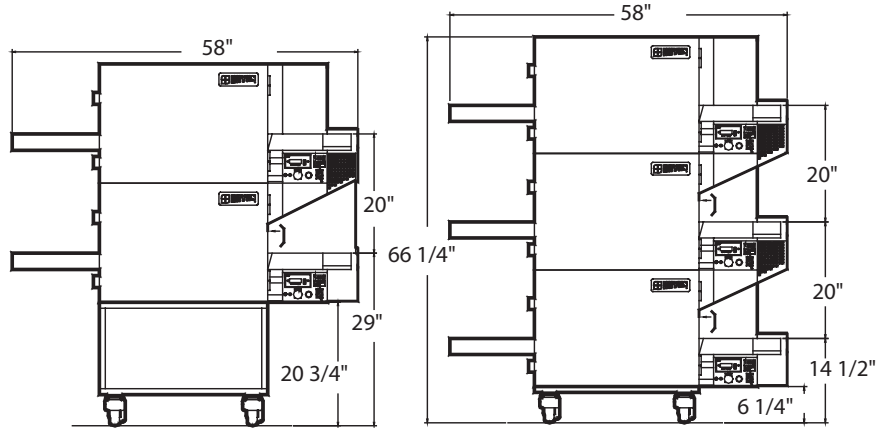

1255, rue Principale  
 Linière, Beauce, Québec, Canada G0M 1J0

Telephone.: 418-685-3431  
 Canada: 1-800-463-1636  
 E-mail : doyon@doyon.qc.ca

Fax: 418-685-3948  
 U.S.: 1-800-463-4273  
 Internet : http://www.doyon.qc.ca



Your local distributor: / Votre distributeur:

