

**Thinline Ovens**

“Superior *quality* product  
at an *affordable* price !”



TLO



**DOYON THINLINE SERIES  
(TLOI & TLOII RACK OVENS)**

The Doyon rack oven is simply your best buy for high volume production. You can either use the single rack (up to 18 pans) or double rack oven (up to 36 pans per load). These ovens are made of stainless steel inside and outside for easy cleaning and durability. They come standard with a digital programmable control which features a high volume manual shot and constant pulse steam injection system. Doyon's TLO series have standard suspended type racks (easy maintenance and cleaning), flat floor ramp for easy loading and unloading, front mounted panel for service and maintenance, space saving units. All our rack ovens are shipped in one piece. Available gas or electric.

**VERSATILITY**

Bread, Rolls, Buns, Pastries, Cookies, Muffins, Pies, Cakes, Bagels, Croissants, Sours and Ryes, Pizza.

## Standard Features

- Manual mode and user friendly programmable control with up to 99 recipes
- Up to 10 steps per recipe
- Temperature up to 500° F (260° C)
- Digital temperature display adjustable in ° F or ° C
- Compact
- Rotating rack for uniform baking
- Rack lifted for rotation
- Unique shot and pulse steam injection
- Two vertical rows of adjustable stainless steel louvers
- Oven door locked at the top and bottom
- Stainless steel inside and outside
- Interior welded and sealed
- Standard Type II hood
- Shipped fully assembled
- Door switch cutoff for fan blower
- Serviceable from front and top
- ETL and NSF listed
- One year parts and labor limited warranty

## OPTIONAL

- Computer interface communication kit for storage of recipe programs on PC and laptop
- TLO racks
- Water softener (WF001)
- Prison package (PPTLO)

## SHIPPING INFORMATION

TLOIE 2600 lb (1180 kg) approximately

TLOIE 3600 lb (1635 kg) approximately

TLOIG 2600 lb (1180 kg) approximately

TLOIG 3600 lb (1635 kg) approximately

- Overheat warning - 1
- Heat ON - 2
- Fan ON - 3
- Pulse steam - 4
- Shot steam - 5
- Temperature ready - 6
- Racks rotation - 7

- Temperature control
- Cooking timer
- Start recipe
- Stop

- Breaker



- Pulse steam
- Shot steam
- Up/Down setting adjustment
- Number of recipes available (1-99)
- Recipe program key pad

# TLO RACKS



RTLOI

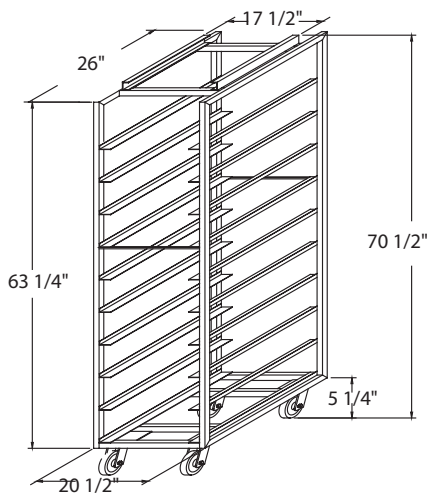

RTLOSL

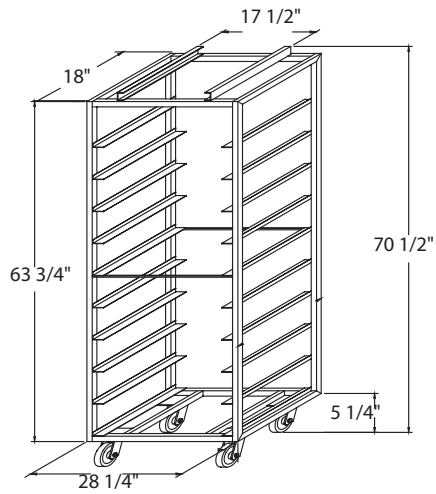

RTLOII

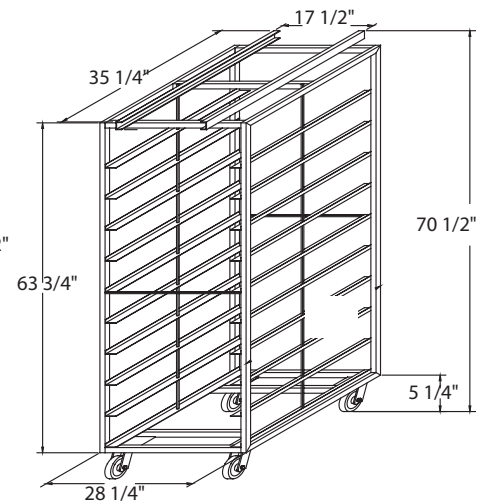

Pan qty	Spacing
10	6 3/16"
11	5 9/16"
12	5 1/8"
13	4 3/4"
15	4 1/16"
18	3 3/8"

Pan qty	Spacing
10	6 3/16"
11	5 9/16"
12	5 1/8"
13	4 3/4"
15	4 1/16"
18	3 3/8"

Pan qty	Spacing
20	6 3/16"
22	5 9/16"
24	5 1/8"
26	4 3/4"
30	4 1/16"
36	3 3/8"

**OVERALL DIMENSIONS**

**TLOIE & TLOIG**

49 1/2" W X 72 1/4" D X 105 5/8" H  
(1255 mm X 1835 mm X 2683 mm)

**TLOIIE & TLOIIG**

60 3/4" W X 82 3/8" D X 105 1/2" H  
(1543 mm X 2092 mm X 2680 mm)

**OVEN INTERIOR DIMENSIONS (wall to wall)**

**TLOIE & TLOIG**

37" W X 39" D X 75" H  
(940 mm X 990 mm X 1905 mm)

**TLOIIE & TLOIIG**

48" W X 50" D X 75" H  
(1220 mm X 1270 mm X 1905 mm)

**ELECTRICAL SYSTEM**

**TLOIE 3 phases:**

- 120/208V - 122A - 44kW - 4 wires - 60 Hz
- 120/240V - 105A - 44kW - 4 wires - 60 Hz
- 220/380V - 74A - 49kW - 4 wires - 50 Hz
- 480V - 52A - 44kW - 3 wires - 60 Hz
- 600V - 42A - 44kW - 3 wires - 60 Hz

**TLOIIE 3 phases:**

- 480V - 75A - 62kW - 3 wires - 60 Hz
- 600V - 60A - 62kW - 3 wires - 60 Hz
- 220/380V - 94A - 62kW - 4 wires - 50 Hz

**TLOIG 3 phases:**

- 120/208V - 8A - 3kW - 4 wires - 60 Hz
- 120/240V - 10A - 3kW - 4 wires - 60 Hz
- 220/380V - 4.1A - 2.7kW - 4 wires - 50 Hz

Gas Info : 200 000 BTUH (Propane or Natural)

**TLOIIG 3 phases:**

- 120/208V - 10A - 3.5kW - 4 wires - 60 Hz
- 120/240V - 10A - 3.5kW - 4 wires - 60 Hz
- 220/380V - 5.1A - 3.3kW - 4 wires - 50 Hz

Gas Info : 300 000 BTUH (Propane or Natural)

**Recommended gas pressure:**

- Propane gas : 11" W.C.
- Natural gas : 7" W.C.

Gas exhaust 6" (152 mm)

**INSTALLATION**

- Unit must be on a level floor. Not approved for installation on combustible floor surfaces.
  - Certified for zero clearance to combustible surface sides and back.
  - Drain connection recommended (located in the back of the unit, close to the floor)
  - Draft hood included with all models
  - Floor must be bolted
  - Electrical, water and gas systems located on top of the unit
- Specifications and design subject to change without notice.

**TLOI**

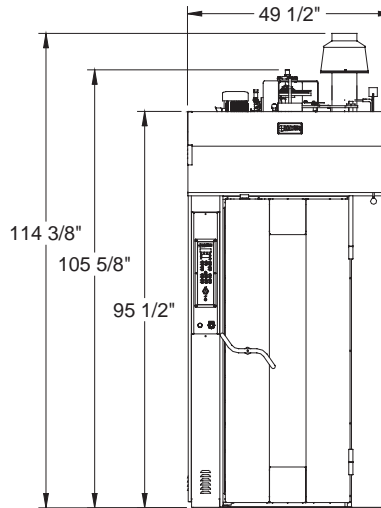

**TLOII**

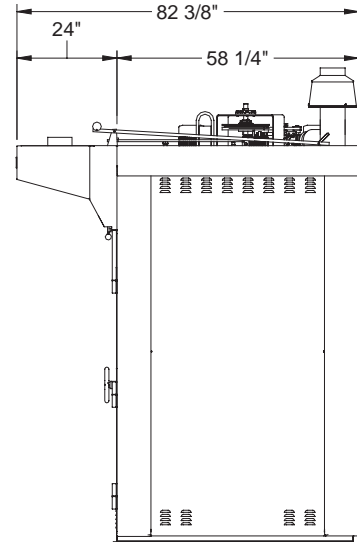
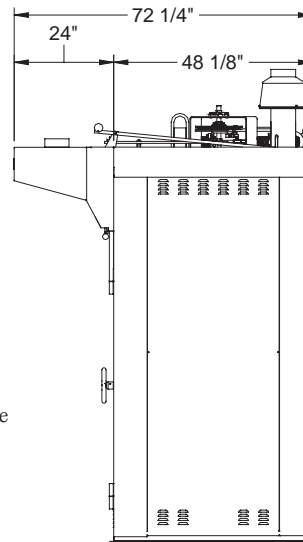
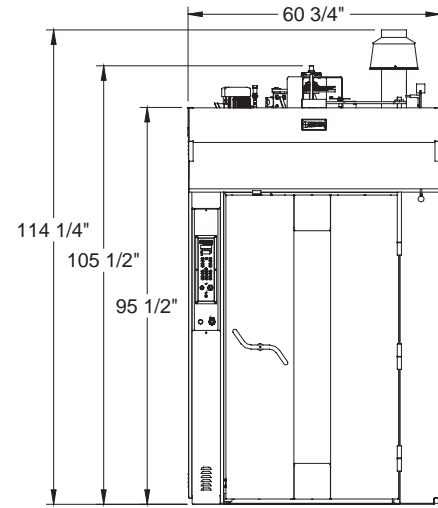

Your local distributor:

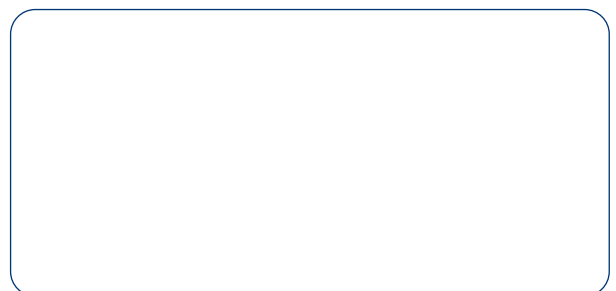

1255, rue Principale  
Linière, Beauce, Québec, Canada G0M 1J0

Telephone : (418) 685-3431 Fax: (418) 685-3948  
Canada : (800) 463-1636 U.S.: (800) 463-4273  
E-Mail : doyon@doyon.qc.ca Internet: http://www.doyon.qc.ca