



JA10
(shown with optional stand)



Standard control



Optional programmable control

JA10

“Superior *quality* product at an *affordable* price !”

Jet Air Oven 10 pans baking capacity

Standard Features

- Outstanding steam shot and pulse injection system
- Exclusive patented reversing fan system
- Two speeds fan
- Fan delay switch
- Compact space saving unit
- High production oven
- Full view heat reflective thermos glass doors
- Brightly lit
- Digital reminder timer
- Fully insulated, completely sealed
- Digital temperature controllers and timers
- Temperature up to a maximum of 500°F (260°C)
- Energy efficient electric or gas heating (baking temperature reached in 15 minutes)
- Magnetic latches
- Door switch cutoff for fan motor
- Stainless steel inside and outside
- 3/4 HP motor
- ETL & NSF listed
- One year parts and labor limited warranty

OPTIONAL

- 4 legs
- Stand with locking casters (JA10B) (20 pans capacity)
- Sliding doors
- Water softener system
- Programmable controls (adds 2" (51 mm) to oven width)
- Gas quick disconnect kit (4' (1120 mm) flexible hose, ball valve and securing device)

JET AIR OVEN (JA10)

The JA Series from DOYON is known worldwide for its unique and patented JET AIR SYSTEM (the air moves in one direction for 2.5 minutes, stops for 25 seconds than moves the other way for 2.5 minutes) resulting in a gentle velocity air flow for exceptional baking results. This system will help you bake faster and more evenly. Our competitors ovens allow the air to move in one direction only.

DOYON's outstanding uniform steam injection system includes an electronic timer which will give you a precise mist everytime for a better quality product (crusty breads, bagels, french baguettes, etc.). This superior steam system will allow inexperienced employees to produce quality products with a minimum of training.

Versatility:

Bread, rolls, buns, crusty breads, pastries, muffins, cakes, pies, bagels, croissants, sours and ryes, bacon, game hens, chicken, turkey, multimeal prep, bulk vegetables/casseroles, slow cook/retherm.

All JA ovens can be used to cook meat

OVERALL DIMENSIONS

JA10 53 1/4" W X 48 3/4" D X 34 5/8" H
 (1353 mm X 1238 mm X 879 mm)
 JA10G 53 1/4" W X 53 5/8" D X 34 5/8" H
 (1353 mm X 1362 mm X 879 mm)

OVEN INTERIOR DIMENSIONS

JA10 39" W X 30 3/4" D X 26 1/2" H
 (991 mm X 787 mm X 673 mm)
 JA10G 39" W X 29 3/4" D X 26 1/2" H
 (991 mm X 756 mm X 673 mm)

Shelf spacing 3 3/4" (95 mm)

GAS SYSTEM (JA10G - Propane or natural)

BTU total: 85 000
 Voltage: 120V - 1PH - 12A - 1.4 kW - 2 wires - 60Hz NEMA 5-15P
 Gas inlet: 1/2" NPT
 Draft hood : 4" (102 mm)

Recommended gas pressure:

Propane gas : 11" W.C.
 Natural gas : 7" W.C.

ELECTRICAL SYSTEM (JA10)

1 Phase:
 120/208V - 65 A - 13.5 kW - 3 wires - 60 Hz
 120/240V - 58 A - 13.5 kW - 3 wires - 60 Hz
 3 Phases:
 120/208V - 43 A - 13.5 kW - 4 wires - 60 Hz
 120/240V - 40 A - 13.5 kW - 4 wires - 60 Hz
 480V - 17 A - 13.5 kW - 3 wires - 60 Hz
 Other voltages available

Water Inlet : 1/4" NPT

Minimum clearance from combustible material
 1" (25 mm) side and back
 4" (102 mm) bottom
 12" (305 mm) top

CAPACITY

Standard sheet pans 18" X 26" (457 mm X 660 mm): 10 pans
 Four-strapped bread pans: 36 loaves
 9" (230 mm) pies: 50 pies

FINISH

Stainless steel

SHIPPING WEIGHT

JA10 950 lb (431 kg) approximately
 JA10G 950 lb (431 kg) approximately
 JA10B 200 lb (90 kg) approximately

Electrical service connection and water inlet are located at the back of the unit.
 Specifications and design subject to change without notice.

JA10

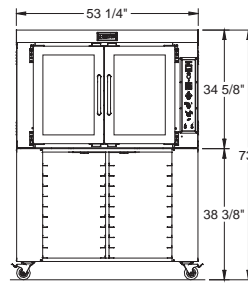

JA10G

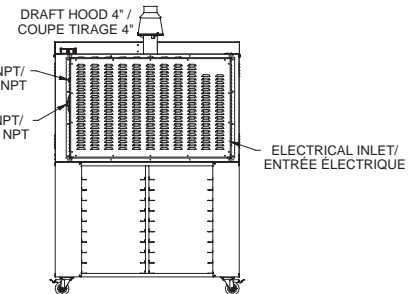
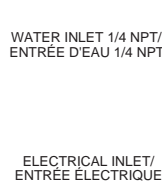
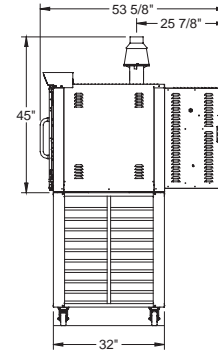
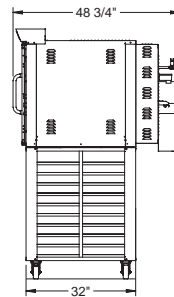
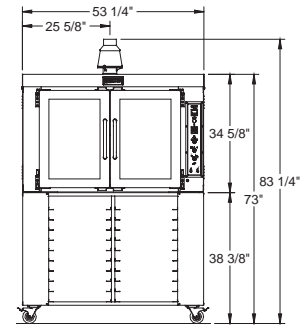

Your local distributor:

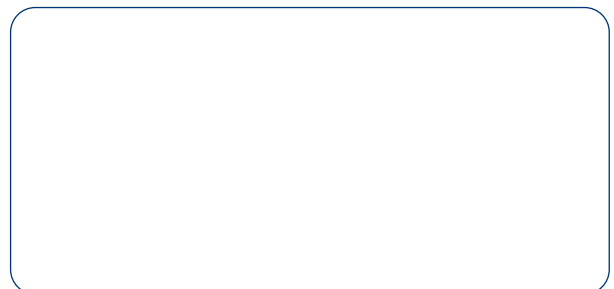

1255, rue Principale
 Linière, Beauce, Québec, Canada G0M 1J0

Telephone : (418) 685-3431 Fax: (418) 685-3948
 Canada : (800) 463-1636 U.S.: (800) 463-4273
 E-Mail : doyon@doyon.qc.ca Internet: http://www.doyon.qc.ca