



FPR3+Stand

## FPR3 Speed-Cook Oven

Doyon's revolutionary FPR3 oven is designed for today's foodservice operators who need a very small (26 1/2" wide), compact design with maximum product throughput, versatility, cooking speed and flexibility.

The Doyon FPR3 oven will brown, toast, broil, bake, poach, boil and air-fry foods in 35% to 40% less time than conventional or convection ovens, but with traditional cook technology. The FPR3 oven achieves impressive results without the use of food damaging microwaves or elaborate engineering that drives up costs and makes servicing and parts expensive. A FPR3 gives a 100% uniform cook without any need to turn pans. Due to the "Jet-Air" cook technology coupled with rotating shelves: no cold spots, perfect even browning. Cooking directly on energy transferring nickel-plated steel shelves drives down cooking times 35% or more. You can easily cook different products together at the same time! A full-view, drop-down glass door provides superior visibility of product cooking and adds to customer impulse sales. You can stack FPR3 units up to 3 high for increased production in just 26 1/2" width. FPR3 outperforms other "Speed-Cook" ovens on the market that cost thousands of dollars more.

You can cook a wide variety of products: toasted sandwiches, appetizers, pizza, chicken wings, quiche, baked potatoes, casseroles, fish, seafood, meats, chicken, ethnic foods, mexican platters/nachos and all types of bakery products such as bread, rolls, croissants, muffins, cinnamon rolls, brownies, cookies, cakes, scones, bagels, biscuits and much more!

The Doyon FPR3 will give foodservice operators greater efficiencies, energy savings, lower costs to produce, a flexible menu of food items and increased profits. Hot, high quality food translates into happy, satisfied customers and more sales!

**FPR3**

*"Superior quality product  
at an affordable price!"*

## "Speed Cook" Oven Standard Features

- "Jet-Air" air flow with patented fan design - Hot recycled air system results in cook times: up to 40% less than any conventional or convection oven
- Stainless steel inside and outside - Superior rust and corrosion resistance. # 6 mirror finish provides superior cleaning and oven compartment light reflectivity and illumination
- Three levels of 3/16" thick, perforated rotating nickel-plated shelves - Shelves accept up to 18" (457 mm) diameter products (17 1/4" (438 mm) on bottom and middle shelves, 18" (457 mm) on top shelf). Superior heat transfer material
- Fast baking : most products cook in 5-6 minutes
- High temperature range - Cook/broil up to 600°F (315 °C)
- Full view glass door - Visibility of product cooking and better impulse sales from customers
- Drop-down door - Fast load and unload, better worker ergonomics, less heat loss, landing ledge
- High impact incandescent lighting - Superior illumination
- Fully insulated and sealed oven compartment - Cooler exterior and longer compartment life
- Digital count-down timer and thermostat - Simple manual control of time and temperature
- Stackable design - Oven expands when you do
- Circuit breakers - No unreliable fuses
- Overheat protection - Protects equipment
- ETL & ETL sanitation listed - All necessary electrical and sanitation code compliance
- One year parts and labor limited warranty - Your assurance Doyon Equipment stands behind the product
- ETL & ETL sanitation listed
- One year parts and labor limited warranty

## OPTIONAL

- Stainless steel table with casters (FPR2T) - 304 stainless steel flat top and bottom shelf, all welded construction, four polyurethane swivel casters - two casters locking
- Square rotating tray in lieu of shelves (FPR2-15) capable of accepting two (2) 12" X 14" (305 mm X 356) trays
- CE listed model

### EXTERIOR DIMENSIONS

26 1/2"W X 26 1/4"H X 36 3/8"D  
(673 mm X 667 mm X 924 mm)

### Clearance to wall:

Back: 4" (101 mm)

Sides: 4" (101 mm)

Legs must remain on

### BAKING CHAMBER DIMENSIONS

19 1/2"W X 19 1/2"D X 9 1/2"H  
(495 mm X 495 mm X 241 mm)

### SPACING BETWEEN DECKS

Between the first (bottom) and second deck : 2 7/8" (73 mm)

Between the second and third deck : 2 3/8" (60 mm)

Between the third deck and the top of the door opening : 2 3/8" (60 mm)

### DOOR OPENING

19 1/2"W X 9"H

(495 mm X 229 mm)

### ELECTRICAL SYSTEM

208V - 1 PH -26 A - 5.4 kW - 2 wires - 50/60 Hz NEMA 6-30P

240V - 1 PH -23 A - 5.4 kW - 2 wires - 50/60 Hz NEMA 6-30P

220V - 1 PH -27 A - 6 kW - 2 wires - 50/60 Hz

Other voltages available

### PRODUCTION PER HOUR (460°F/238°C - 5 min)

60 6" (152 mm) Pizzas

40 9" (228 mm) Pizzas

30 17" (432 mm) Pizzas

102 toasted italian subs

54 mexican platters

50 nacho platters

112 biscuits

96 chicken breasts

12 18" (457 mm) pizzas

### FINISH

Stainless steel inside and outside

### SHIPPING WEIGHT

FPR3 :385 lb (152 kg) approximately

FPR2T : 75 lb (34 kg) approximately

Doyon Equipment Inc reserves the right to make any substitutions of components, engineering changes and any changes to specifications without any prior notice for purpose of offering product improvements.

Multiple patents submitted, approved and/or pending.

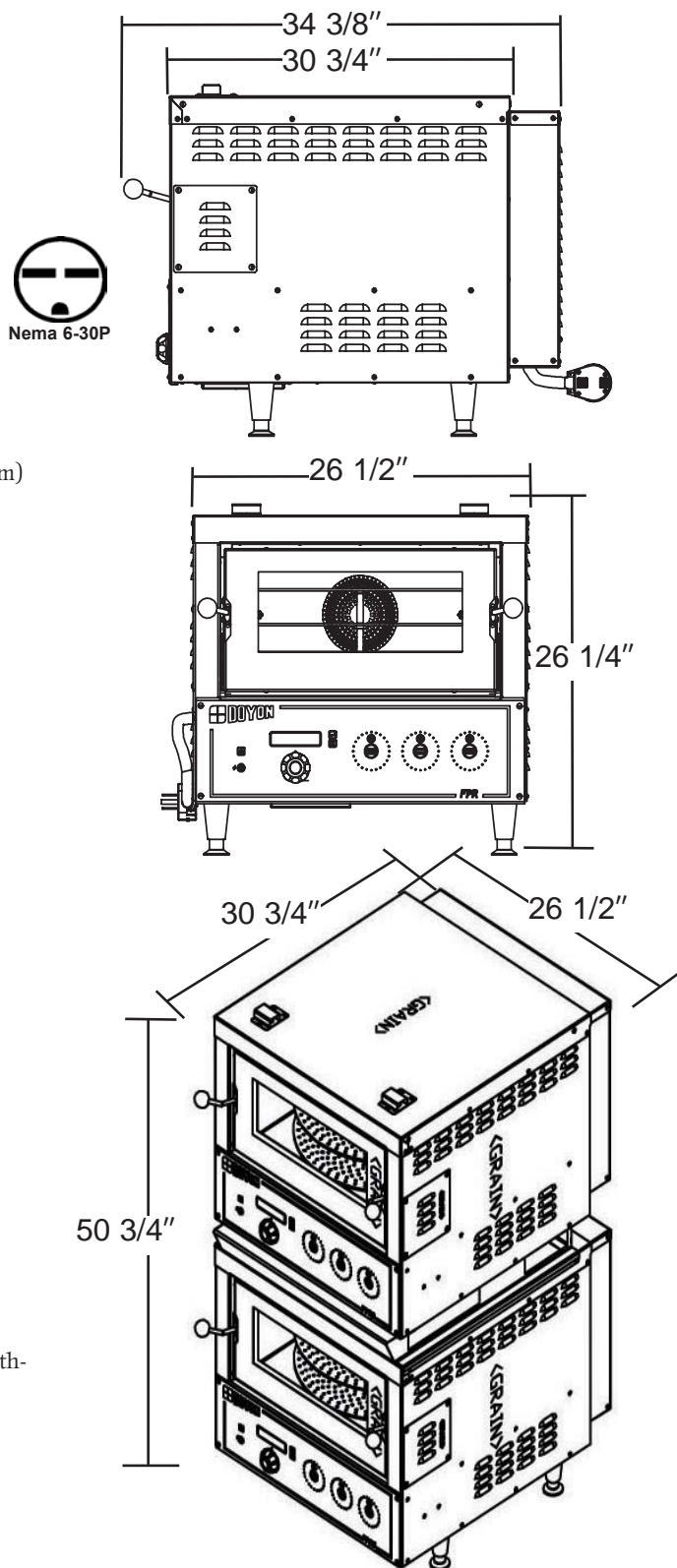

Your local distributor:

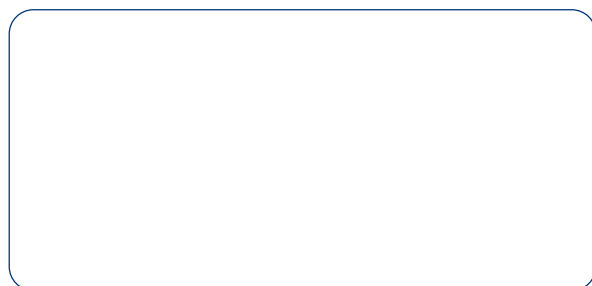

1255, rue Principale  
Linière, Beauce, Québec, Canada G0M 1J0

Telephone : (418) 685-3431 Fax: (418) 685-3948  
Canada : (800) 463-1636 U.S.: (800) 463-4273  
E-Mail : doyon@doyon.qc.ca Internet: http://www.doyon.qc.ca

[www.doyon.qc.ca](http://www.doyon.qc.ca)