



FPR2

FPR2 Rotating Pizza Oven

Doyon's FPR2 model is the most advanced "Jet Air" compact oven, with rotating shelves, known for its 100% uniform baking and a display oven that no one can match. Bake directly on the rotating nickel plated perforated shelves in 25% to 45% less time than traditional deck ovens. No cold spots. Save from 35% to 65% in energy costs versus deck ovens.

Fully insulated and sealed, with easily removable shelves, the FPR2 is easy to clean.

VERSATILITY

Pizza, bread, pastries, cookies, croissants, chicken, cakes, muffins, pies, meat, etc ...

FPR2

"Superior *quality* product
at an *affordable* price!"

Rotating Pizza Oven

Standard Features

- Stainless steel inside and outside
- Jet Air convection oven
- Rotating trays
- Fast baking : 5-6 minutes at 460 °F (238 °C)
- Capacity of 1 X 18" (457 mm) and 1 X 16" (406 mm) pizzas
- Full view glass door
- 100% uniform baking
- Brightly lit
- Compact space saving unit
- Hot recycled air system
- Fast and even baking
- Direct baking on rotating plate
- Easy cleaning
- Easily removable top shelf to bake bigger products
- ETL & ETL sanitation listed
- One year parts and labor limited warranty

OPTIONAL

- Stainless steel table with casters (FPR2T)
- 2 X 18" (457 mm) pizzas capacity
- Square rotating tray (FPR2-15) capable of accepting two (2) 12" X 14" (305 mm X 356) trays
- CE listed model

DIMENSIONS

26 1/2"W X 34 3/4"D X 26 1/4"H
(673 mm X 883 mm X 667 mm)

INTERIOR DIMENSIONS

19 1/2"W X 19 1/2"D X 9 1/2"H
(495 mm X 495 mm X 241 mm)

DOOR OPENING

19 1/2"W X 9"H
(495 mm X 229 mm)

ELECTRICAL SYSTEM

208V - 1 PH -26 A - 5.4 kW - 2 wires - 60 Hz NEMA 6-30P
240V - 1 PH -23 A - 5.4 kW - 2 wires - 60 Hz NEMA 6-30P
220V - 1 PH -27 A - 6 kW - 2 wires - 50 Hz

Other voltages available

PRODUCTION PER HOUR (460°F/238°C - 5 min)

60 6" (152 mm) Pizzas
40 9" (228 mm) Pizzas
20 16" (406 mm) Pizzas

FINISH

Stainless steel inside and outside

SHIPPING WEIGHT

FPR2 :335 lb (152 kg) approximately
FPR2T : 75 lb (34 kg) approximately

Specifications and design subject to change without notice.

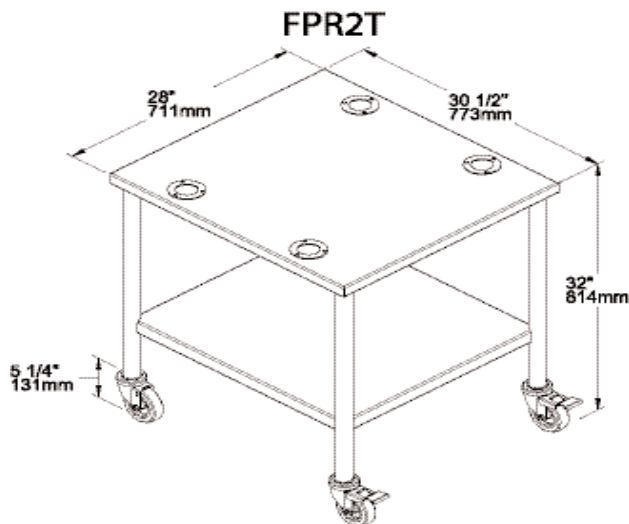
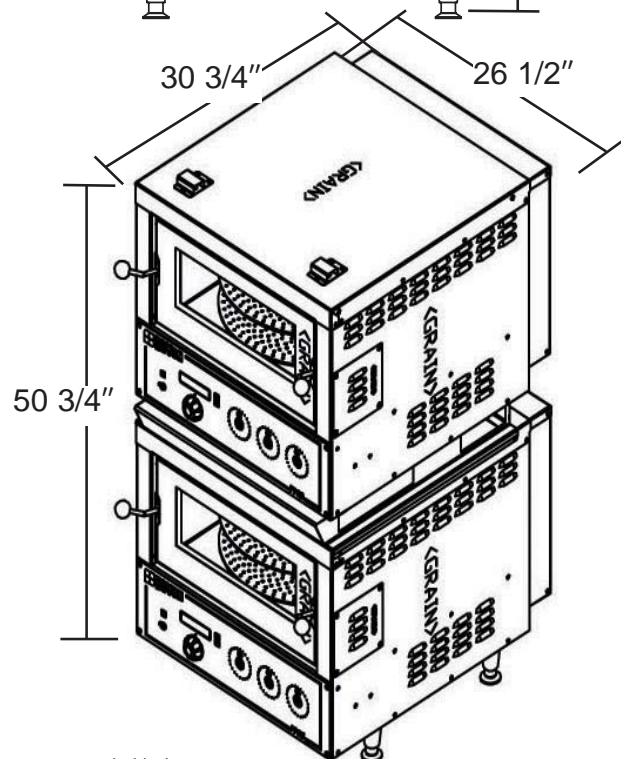
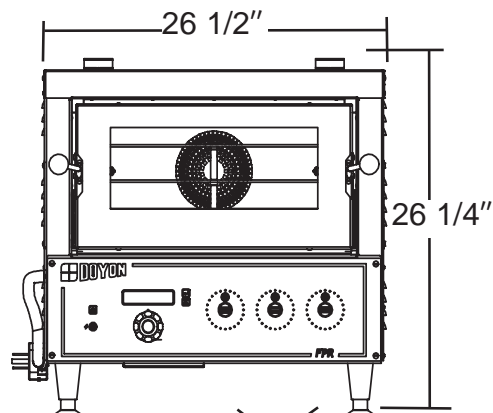
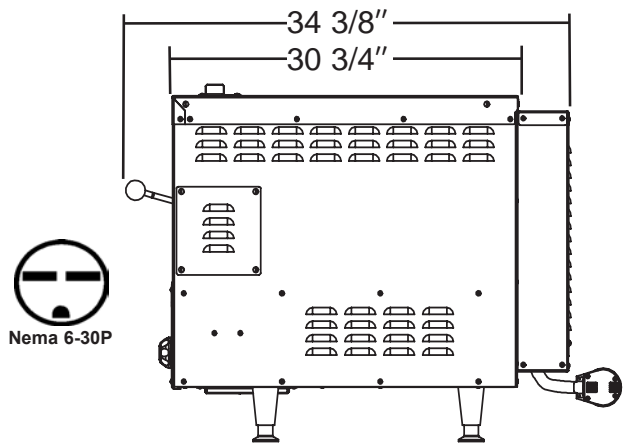

Your local distributor:

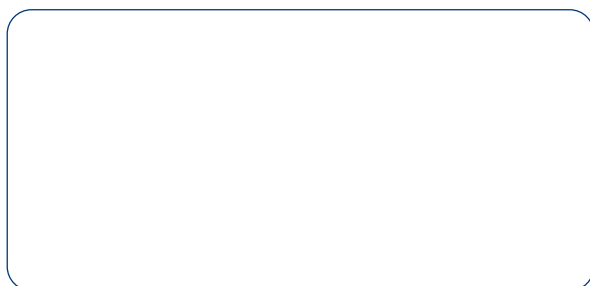

1255, rue Principale
Linière, Beauce, Québec, Canada G0M 1J0

Telephone : (418) 685-3431 Fax: (418) 685-3948
Canada : (800) 463-1636 U.S.: (800) 463-4273
E-Mail : doyon@doyon.qc.ca Internet: http://www.doyon.qc.ca